

SILOTEC®

Real-time smouldering fire monitoring in silos

DEVELOPED AND
MANUFACTURED
IN GERMANY



DASTEC S.R.L.

Representantes / Distribuidores Exclusivos

 **Argentina**

Tel: (+54 11) 5352 2500

Email: info@dastecsrl.com.ar

Web: www.dastecsrl.com.ar

SILOTEC® **FAST SAFETY MEASUREMENT**

Designed for continuous monitoring in coal silos and others containing potentially combustible dust hazards, SILOTEC 8000 meets ATEX Zone 20 requirements and offers long-term operation without any maintenance.

The most important gas molecule to monitor for smouldering fire protection is CO.

The second most important gas molecule is O₂ as it gives an indication of the inert conditions in the silo, and is always related to CO if a fire is present. If O₂ and CO are measured simultaneously, smouldering fires can be detected and the efficiency of the inertisation is monitored.

- > Fast smouldering fire monitoring and inertisation in silos
- > Direct CO and O₂ measurement for ATEX Zone 20
- > Plug & Play turn-key solution for silos
- > Maintenance-free operation
- > Functional safety: certified to SIL2
- > Reliable system for increased plant safety
- > Automated self-diagnosis and cleaning
- > Simple retrofit solution

Compared to other solutions on the market for this application, SILOTEC 8000 is installed directly on the silo roof where the sensor is situated and where measurement takes place. This enables a fast response time which is necessary for safety monitoring.

After installation and commissioning, the measurement does not require any maintenance. Automatic calibration and the optional blow-back ensure highest reliability and accurate measurement with no drift.



Fig. SILOTEC 8000 analyzer system

SILOTEC®

TECHNICAL DETAILS

CO / O ₂ RANGES	0 to 5000 ppm CO 0 - 25 % O ₂ (others on request)	INTERFACE	HART, FIELDBUS, RS485, MODBUS RTU, RS232, ENOTEC REMOTE
SENSOR ACCURACY CO	better ±5 % of range end	AMBIENT TEMPERATURE	-20 °C to 55 °C
SENSOR ACCURACY O ₂	± 0.2 % of measured value	IP CODE	IP 65
REACTION TIME	< 0,5 s	ATEX	Zone 20

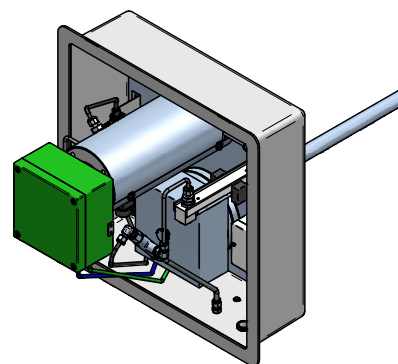
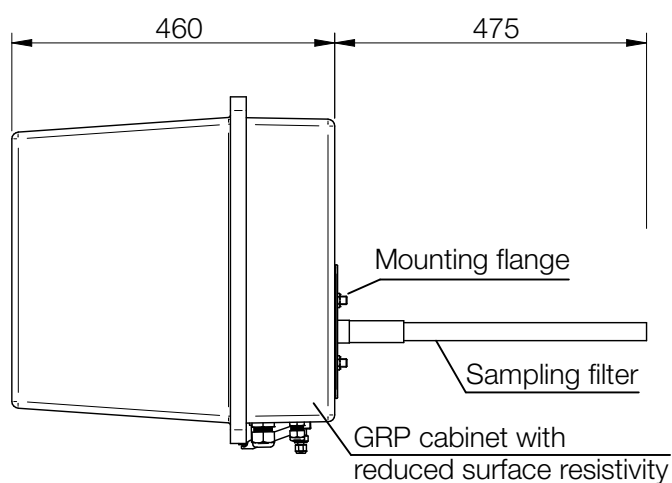

Fig. SILOTEC probe

SILOTEC®
SAFE PROCESS

COMPANY

ENOTEC has provided gas sensing solutions since 1980, producing products with a high degree of accuracy, quality and durability - Made in Germany.

Our flexibility allows us to quickly develop solutions individually designed to meet your requirements.

On request, we also offer after delivery service concepts - the world over.

SYSTEM FEATURES

- > Automatic calibration as standard
- > Effective automated blow-back
- > CO and O₂ limit alarms
- > SIL2 safety certification
- > ATEX Zone 20 compliant

CONTACT

ENOTEC GmbH
Höher Birken 6
51709 Marienheide
Germany

Phone: +49 (0) 22 64 45 78 0
Fax: +49 (0) 22 64 45 78 30

E-mail: info@enotec.com
Web: www.enotec.com

ENOTEC has four subsidiaries: ENOTEC USA, ENOTEC ASIA, ENOTEC UK, ENOTEC OOO and over 50 distributors world wide...



ENOTEC REMOTE APP
Simple control of ENOTEC analyzers



[enotec-sensors](https://www.linkedin.com/company/enotec-sensors)



Watch the ENOTEC product videos on our YOUTUBE channel
www.youtube.com/ENOTECsensors