

SENTRY RX SAMPLER

Strip Samplers

DASTEC S.R.L.

Representantes / Distribuidores Exclusivos

Buenos Aires, Argentina

Tel.: (54 - 11) 5352-2500

Email: info@dastecsr.com.ar

Web: www.dastecsr.com.ar

AUTOMATIC SAMPLING

The Sentry® RX automatic strip sampler automates sampling of dry free-flowing materials such as granules, powders, flakes, pellets, grain or seed from positive or negative pressure systems, gravity chutes and hoppers. A strip sampler captures a sample strip across the diameter of a process stream, and is used in situations where material segregation exists.

To obtain a sample, the Sentry RX sampler's air cylinder moves a sample probe into the process stream. While in line, the tube continuously takes sample and discharges it through a flexible hose to a collection point. Material characteristics are not affected by the sampler because no moving parts convey the sample to the sample container. Sample volume can be changed at the sampler controller.

MODELS

RX

BENEFITS

With representative sampling, characteristics of each sample match that of the entire lot or batch—so samples are repeatable, leading to accurate sample analysis data. Automatic sampling ensures a sample can be easily and safely obtained with no need for direct human interface or interference. This ensures sample integrity as well as operator safety.

FEATURES

- Customized to meet various application needs
- Tube retracts from the line to avoid any restriction in the product flow
- Wetted components are 300 series stainless steel
- UHMW or PTFE seals
- White nitrile seals or gaskets
- Designed to eliminate the degradation of sample material
- Compact and low maintenance
- No moving parts in conveyance from sampler to container, keeping material characteristics consistent
- Versatile design installs in drop chutes, bins, hoppers, pipes or air slides
- Stroke lengths of 4, 6, 8, 10 and 12 inches (102, 152, 203, 254 and 305 mm)
- CE and ATEX compliant models available
- Available with pneumatic or electric actuation for flexibility
- Includes air filter, regulator and gauge where applicable
- Optional release coating to ensure a non-stick surface
- QPQ hardening of contact surfaces available to protect against wear and abrasion
- Explosion proof (XP) motor available
- Custom mounting adapters for round, square or other shaped chutes or pipes
- Optional sample tube purge
- Pre-plumbed filter/regulator and solenoid valve available
- Optional purge ring for tube exterior
- All stainless steel housing and rails available



Sample. Monitor. Measure.



SENTRY

Any Application. Anywhere.

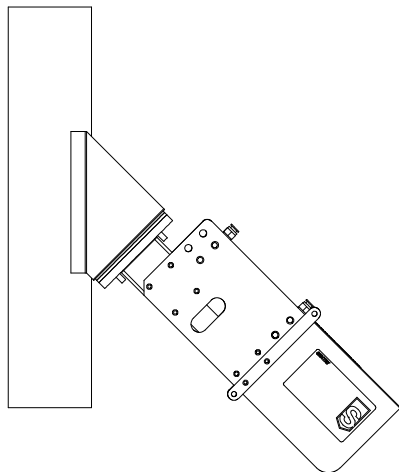

VERTICAL CONVEYING LINE

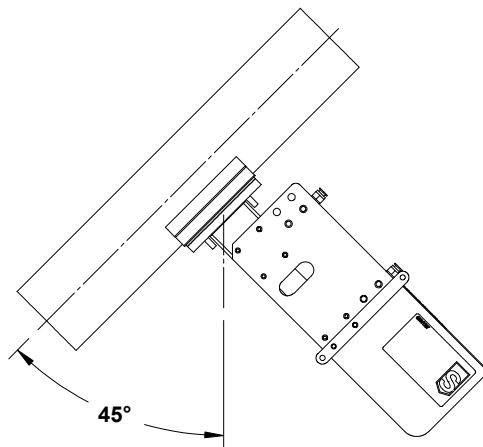

ANGULAR CONVEYING LINE

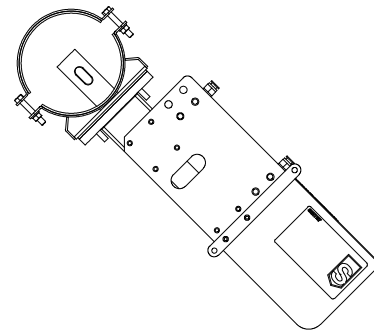

HORIZONTAL CONVEYING LINE

SPECIFICATIONS

materials	300 series stainless steel, UHMW-PE, PTFE, white nitrile, aluminum cylinder
particle size	10 µm to 1/4 in (6 mm)
temperature rating	-10 to 175°F (-23 to 79°C)
air requirements	air pressure of 60 to 80 psi (4.1 to 5.5 bar) recommended; air usage 32 in ³ (524 cc) per inch of stroke
suggested connection to sample discharge	flexible tubing to a collection container or indexing cabinet
recommended sampler location	positive or negative, horizontal or vertical dilute phase pneumatic conveying systems, bins, gravity spouts or hoppers
quantity of sample	determined by flow rate and retract time
collection containers	PET jar, 304 stainless steel jar, bag
pressure rating	up to 30 psi (2.1 bar)
shipping weight	approx. 20 lb (9 kg) for 4-inch (102 mm) stroke to 30 lb (14 kg) for 12-inch (305 mm) stroke

DASTECSRL

Representantes / Distribuidores Exclusivos

Buenos Aires, Argentina
 Tel.: (54 - 11) 5352-2500
 Email: info@dastecsrl.com.ar
 Web: www.dastecsrl.com.ar

sentry-equip.com

966 Blue Ribbon Circle North, Oconomowoc, WI 53066 U.S.A. | +1-262-567-7256 | sales@sentry-equip.com

© 2016 Sentry Equipment Corp. All rights reserved. All product and company names are property of their respective owners. It is solely the responsibility of end users, through their own testing and analysis, to select products and materials suitable for their specific application requirements, ensure they are properly installed, safely applied and properly maintained, and to limit their use to their intended purpose. Improper selection, installation or use may result in personal injury or property damage.

S-SP-SPS-00175-8 6-16



COMPANY WITH
 QUALITY SYSTEM
 CERTIFIED BY DNV GL
 = ISO 9001 =