

### Application Phenolic resin manufacturing

**Targets:** Phenolic resin, resin, and polymer manufacturers

#### Application

Polymers are high molecular mass molecules composed of repeating units called monomers that are connected by covalent chemical bonds. A batch is mainly composed of monomers and has a low viscosity. After adding a catalyst and / or heat, the polymerization process starts and viscosity increases. **Viscosity is an indirect means of measuring the molecular mass of polymers.**

#### Simplified polymerization principle

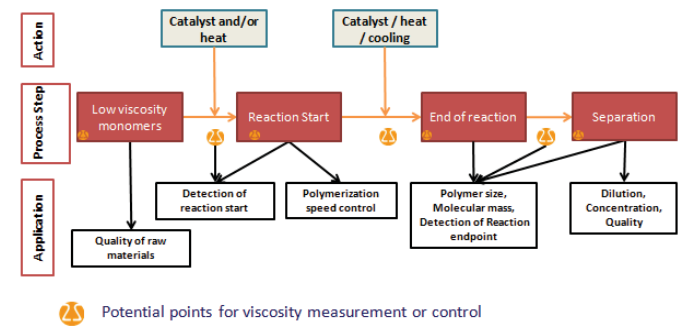

Phenolic resins are often produced for gluing and paper impregnation. They exhibit ideal product characteristics in terms of toughness and material resistance but also present difficult production conditions regarding its reaction process. The various ingredients come from several suppliers so batches are never exactly the same. Each batch is weighed before mixing and then heated in a reactor for a production cycle. During this cycle, the solution's temperature and viscosity are key parameters. Since the reaction is exothermic, it will continue to heat even after the heating process is halted. The heating process has specific phases and has very sensitive temperature and viscosity values that require observation. Should any discrepancy arise and the resin become hard, the result is not only an unusable product, but potential damage to the pipes and reactors.

#### Challenges

- If the exothermic phenolic resin polymerization reaction occurs too quickly, it results in:
  - poor polymer quality (heterogeneous)
  - polymer hardening (impossible to stop the reaction)

**This causes enormous raw material losses, extensive downtime for complicated maintenance, increased labor costs, delivery delays and sometimes enormous replacement costs.**

- If the reaction is too slow, the result is:
  - low productivity (time loss, energy consumption)
  - absence of final product (product does not meet specifications)
- Viscosity is a physical property of the product and the reaction must stop exactly when the required viscosity is reached. When this happens:
  - the product is ready to be used (molded, laminated, extruded, ...)
  - the product can be stocked (resins, glues, polystyrene, polyurethane, polyisobutylene, methylmethacrylate, ...)

Viscosity related issues in batch process polymerization are: raw materials control, reaction start detection, polymerization speed control, molecular weight measurement, chain length characterization, reaction end-point detection, polymer dilution control, concentration, and finished product quality control.

## Solution

The installation of an inline MIVI process viscometer allows easy monitoring of the polymerization reaction end-point, helps determine the correct viscosity and temperature parameters, and prevents mass solidification.

### Installation

The Sofraser MIVI sensor can easily be fitted:

- on a reactor wall
- on a bypass loop
- in an immersion tube

The electronics or controller allows the operator to see, in real time, the viscosity and temperature values and to oversee correct and safe batch process operation.

### Operation diagram of a MIVI sensor on a semi-batch MMA/MA solution copolymerization reactor system

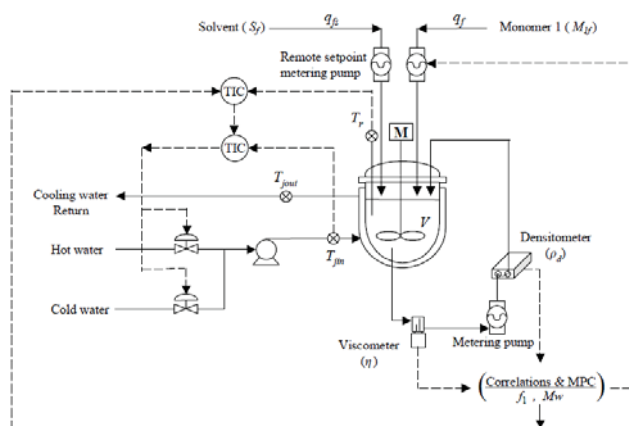

Source: School of Chemical Engineering and Institute of Chemical Processes, Seoul National University

### MIVI viscometer capabilities

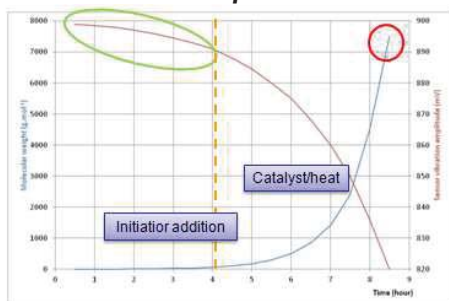

Very good sensitivity in **low viscosities**

Detection of reaction endpoint: **high viscosity, high temperature and control capabilities**

Only one sensor is able to provide such sensitivity in a very large measurement range

### Onsite installation directly on the reactor wall

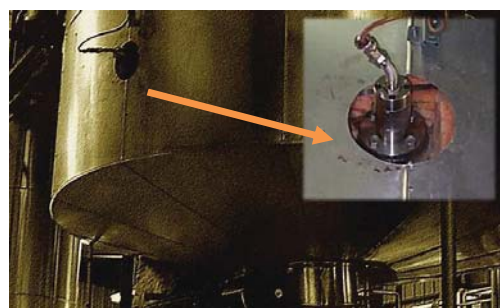

### Key product characteristics

- Good sensitivity at low viscosity combined with high full scale range
- Repeatable and reliable
- Easy to install and variety of mounting positions
- No maintenance, no wearing parts, and no drift in time
- Self cleaning
- Ex-proof certifications
- Resistance to overshoots, alarms for control
- Temperature probe
- Many different coatings for corrosive materials
- High pressure

**DASTEC S.R.L.**

Representantes / Distribuidores Exclusivos  
Buenos Aires, Argentina  
Tel.: (54 - 11) 5352-2500  
Email: info@dastecsr.com.ar  
Web: www.dastecsr.com.ar